

ROTATOR GR-60FD-2

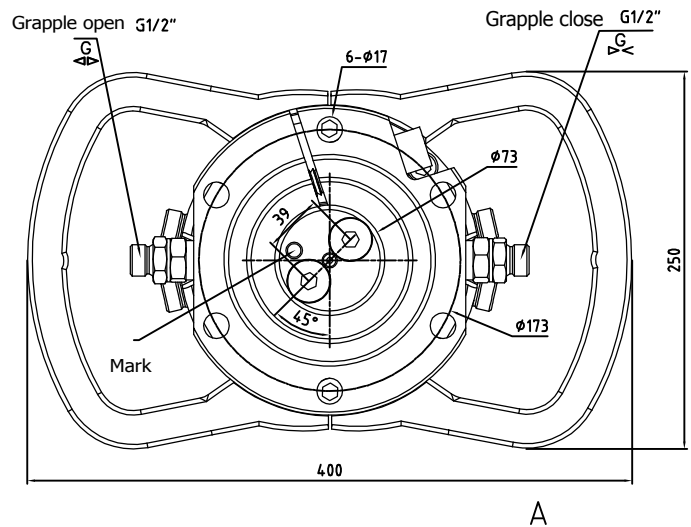
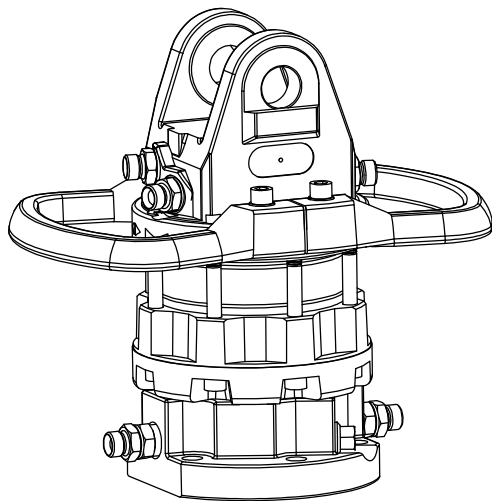
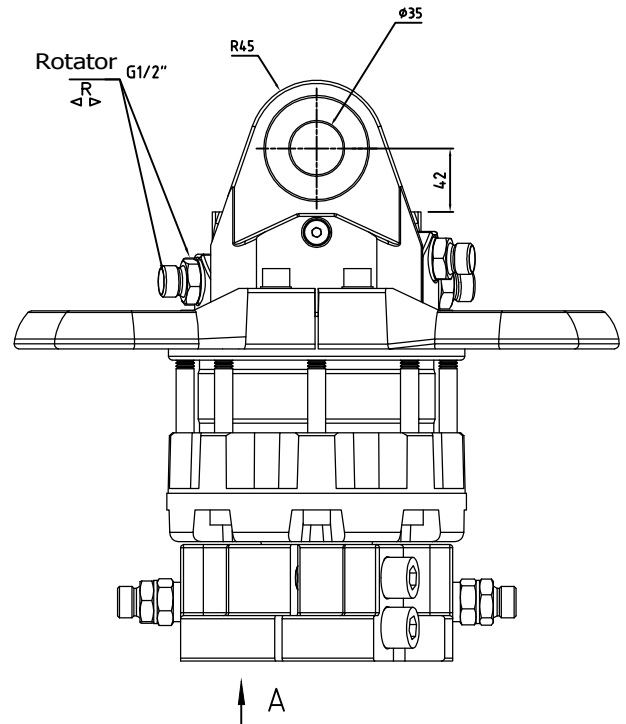
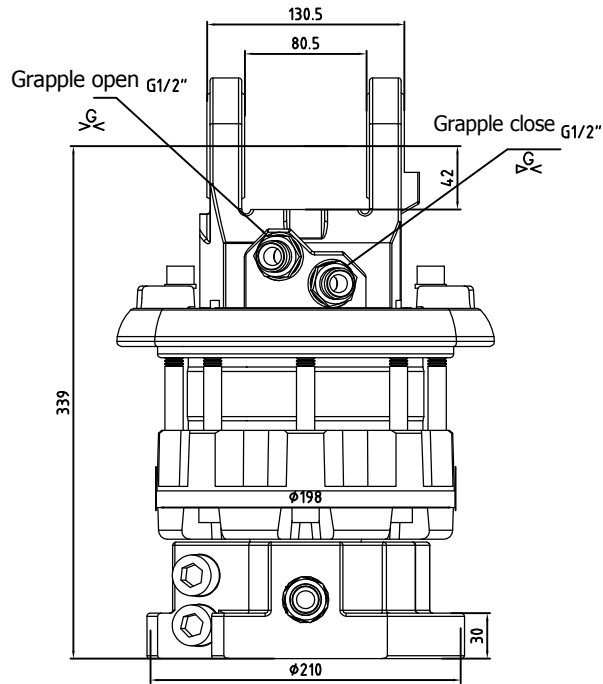

Technical data

Rotation :	Unlimited
Max axial load static,KN:	60
	-50
Max axial load dynamic,KN:	30
	-25
Torque (25MPa) ,Nm:	1800
Rated displacement,ml/r:	678
Weight,Kg:	61
Max working pressure	Connection
Rotator : ←R →	G1/2"
Grapple/Tool open : ←G →	G1/2"
Grapple/Tool close: →G ←	G1/2"

RIMA

Xibeiyu Industry Zone, Laizhou, Shandong, China
 Tel:+(86)-186 6387 9840 Fax:+(86)-535-6805690
 E-mail:info@rimamach.com